

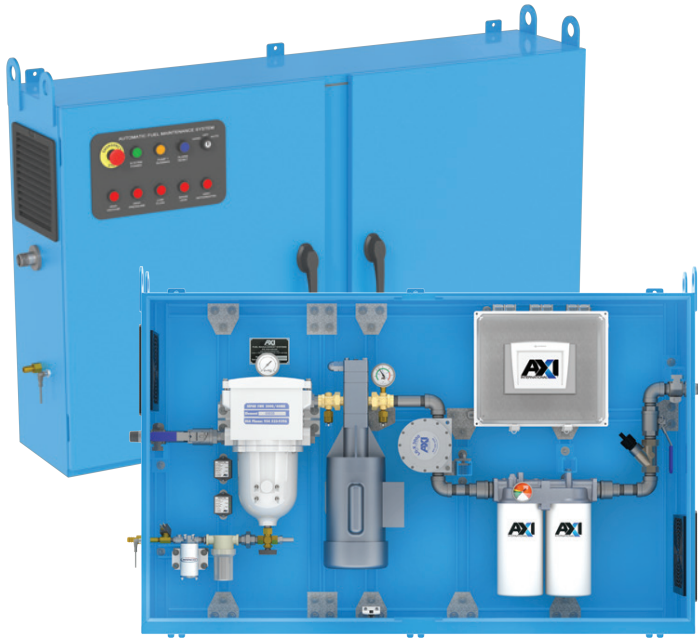

STS 7010

Enclosed Automated Fuel Maintenance Systems

The STS 7010 Programmable Automated Fuel Maintenance System is designed to optimize and maintain diesel fuel indefinitely. Adding an STS 7010 system will remove particulate, separate water, and condition stored fuel. This innovative process stabilizes diesel and bio-fuels, eliminates microbial contamination, and ensures clean reliable fuel at all times. Generators and pumps operating in remote locations are ideal applications for STS 7010 systems.



◆ STS 7010 SPECIFICATIONS

| | |
|--|--|
| Flow Rate (@60Hz) | 10 GPM/600 GPH (37.9 LPM/2271 LPH) |
| Primary Filter/Water Separator | 10 or 30µ Particulate or 60µ Stainless Steel Screen with Centrifugal Water Separator |
| Secondary Filter(s)/ Water Block | 1, 3, 10 or 25µ Particulate or 3, 10µ Water Block |
| Fuel Conditioner | LG-X 3000 Inline Conditioner |
| System Controller | HMI PLC Controller with Touch-Screen and Remote Monitoring, Modbus, TCP/IP LAN and Internet Capability |
| Pump | 3/4 HP Gear Pump |
| Power | 120V/60Hz/15A or 230V/50Hz/15A |
| Plumbing | Stainless Steel |
| Ports | 1" NPT In 1" NPT Out |
| Enclosure Cabinet | NEMA 12 (IP55), 13 (IP65), 4 (IP66), and 4X (IP66) Powder Coat or Stainless Steel |
| Dimensions | 37" x 60" x 12" (H x W x D) (94 x 152 x 30 cm) |
| Weight | ≈ 520 lbs (235.9 kg) |
| Not for use with fluids that have a flash point below 100°F (37.8°C). | |

◆ STS 7000 SERIES SAFETY FEATURES:

- Automatic Alerts
- Pump Shut Down When Filters Need Service
- Leak Detection
- Water Detection
- High Pump Vacuum
- High Pump Pressure
- Low Fuel Flow Alert
- Emergency Stop

◆ SMART FILTRATION CONTROLLERS:

- Modbus, TCP/IP, LAN and Internet Capability
- Email & SMS Maintenance Alert Capability
- Maintenance Alert Log File
- Runtime Totalizer
- Alarm History
- On-Screen Help

◆ STS 7010 FEATURES:

- Multi-stage Water Removal and Particulate Filtration
- NEMA 12,13, 4, 4X Powder Coated or Stainless Enclosure
- UL508A Smart Filtration Controller
- Stainless Steel Plumbing



1.239.690.9589
1.877.425.4239 Toll Free
www.AXI-International.com

AXI.International

AXInternational

AXIFuel

AXIFuel

REV0201701001200

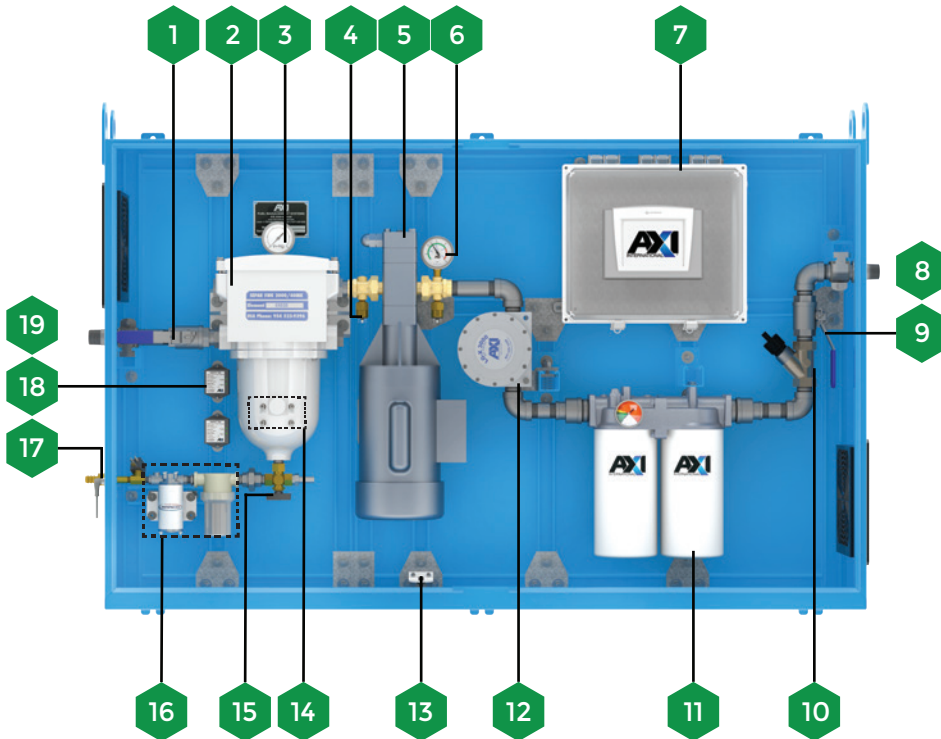

1. Inlet Ball Valve
2. Pre Filter/Water Separator
3. Vacuum Gauge
4. Vacuum Switch
5. Pump
6. Pressure Switch with Gauge
7. Smart Filtration Controller
8. Fuel Outlet (Discharge)
9. Outlet Ball Valve
10. Flow Switch
11. Fine Filter(s)
12. AXI Inline LG-X 3000 Conditioner
13. Leak Detector
14. Water Level Probes
15. Water Drain Valve
16. Auto Water Drain (Optional)
17. Waste Water Outlet (Optional)
18. WATECT Water Sensor
19. Fuel Inlet (From Tank)

STS 7010 OPTIONS:

- AFC 705/710 Fuel Catalyst
- Automatic Water Drain System
- Stainless Steel Enclosure
- Multi-Tank (Up to 4 Tanks)
- Cabinet Heater
- Cabinet Color Options
- Stand

REPLACEMENT FILTER OPTIONS:

| Pre Filter | Part No. | Fine Filter | Part No. |
|-------------------------|----------|-----------------------------|----------|
| 10 μ Filter Element | 04010 | 3 μ Water Block Filter | WB-3 |
| 30 μ Filter Element | 04030 | 10 μ Water Block Filter | WB-10 |
| 60 μ Filter Element | 04060S | 1 μ Fine Filter | FF-1 |
| | | 3 μ Fine Filter | FFZ-3 |
| | | 10 μ Fine Filter | FF-10 |
| | | 25 μ Fine Filter | FF-25 |

STS SYSTEM INTEGRATION:

